

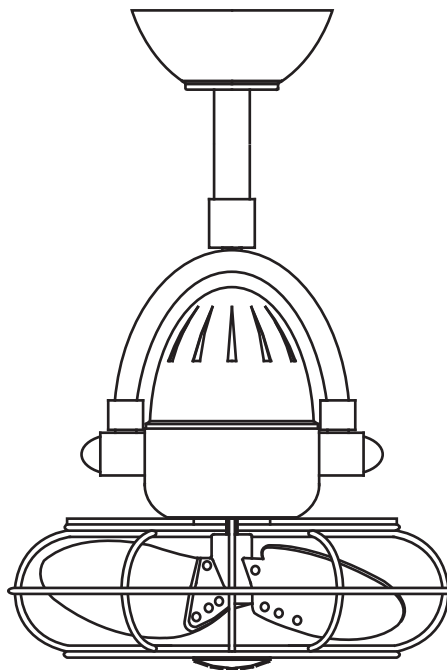

Diane

Ceiling Mounted Oscillating Directional Fan

READ AND SAVE THESE INSTRUCTIONS



AC-MGB2 (Diane)
FAN RATING AC 220-240V~,
50-60HZ, 55W
Net Weight: 4.8Kg

QUICK ASSEMBLY NOTES:

- * Do not wire in fan while house wires are Live, turn power off at breaker before installation begins.
- * Do not use any controls, wall or remote, other than what we provided.
- * Please do not use any electric or battery powered tools in the assembly and installation of this or any Matthews Fan Company product.

AUSTRALIA ONLY

TOOLS AND MATERIALS REQUIRED

- Philips screw driver
- Standard, flat-head screw driver
- 11 mm wrench
- Step ladder
- Wire cutters

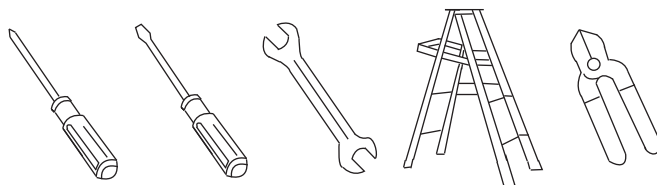

PACKAGE CONTENTS

Unpack your fan and check the contents. You should have the following items:

- a. Hanger bracket assembly
- b. Ball / down rod assembly
- c. Fan motor assembly
- d. Metal blade with cage (decorative* or safety**) or Wood blade
- e. Receiver with 6 wire nuts
- f. Transmitter+holder+2 mounting screws
- g. 1.5V AAA batteries (2)
- h. Allen wrench
- i. Package hardware
 - 1) Mounting hardware:
wood screws (2), screws (2), lock washers (2), washers (2), star washers (2), wire nuts (3)
 - 2) Safety cable hardware:
(wood screw)

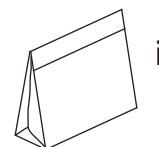
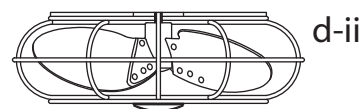
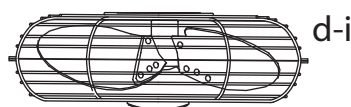
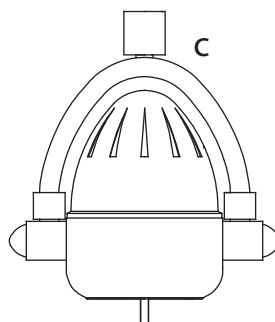
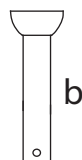
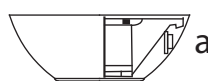

To reduce the risk of injury to persons, install fan so that blades are at least 2.1m above the floor.

READ AND SAVE THESE SAFETY AND INSTALLATION INSTRUCTIONS.

Consult a licensed electrician if unsure of any point below mentioned.

DANGER/WARNING/CAUTION

1. High voltage and moving parts around motors and motor driven equipment can cause serious or fatal injuries. Always disconnect power source at main switch before wiring, servicing or cleaning unit. Do not rely on fan control device to prevent unexpected start-up or electrical shock. In addition, power supply must have fuses or circuit breakers for short circuit protection.
2. All electrical wiring must conform to national and local electrical codes such as: NEC, OSHA, etc. In Australia must be performed by a qualified persons and confirm with AS/NZS 3000 wiring rules.
3. Fan should be secure in its electrical grounding to avoid possible electrical shock.
4. Fan should not be used in any wet or hazardous location defined by article 500 of the NEC. In addition, its ambient temperature should not exceed 104 degrees Fahrenheit.
5. Power supply should conform to voltage rating of 220-240V~ 50-60Hz.
6. Before applying power, visually re-inspect the installation. Make sure that all guards and protective devices are securely in place and all visible screws and bolts are tightened.
7. **Caution:** To reduce the risk of injury to persons, install the fan so that bottom edges of fan blades are to be at least 2.1 m above the floor.
8. To reduce the risk of personal injury, do not bend blades or any other part of fan when cleaning. Do not insert foreign objects in between rotating fan blades or in space surrounding entire rotating fan unit. Fan must be turned off at power at supply source before installation, cleaning or servicing.
9. **Instructions for Supply Connections:** Conductor of a fan identified as grounded conductor to be connected to a grounded conductor of a power supply, conductor of fan identified as ungrounded conductor to be connected to an ungrounded conductor of a power supply, conductor of fan identified for equipment grounding to be connected to an equipment-grounding conductor. After making the wire connections in junction box, the splices should be turned upward and pushed carefully into the outlet box. The wires should be spread apart with the grounded conductor and the fan-grounding conductor on one side of the junction box and the ungrounded conductor on the other side of the outlet box. Be sure that all wiring connections are properly insulated from each other and any surrounding metal parts. For safety and best operating results, only qualified electrician allows to assemble and install your fan.
10. To reduce the risk of personal injury, install the supplementary mounting means and use only the hardware provided with the fan.
11. The mounting of the suspension system shall be performed by the manufacturer, its service agent or suitably qualified persons.
12. Disconnection must be incorporated in the fixed wiring in accordance with the wiring rules.
13. The replacement of parts of the safety suspension system device shall be performed by the manufacturer, its service agent or suitably qualified persons.
14. The fixing means for attachment to the ceiling such as hooks or other devices shall be fixed with a sufficient strength to withstand 4 times the weight of the ceiling fan.

15. **WARNING:** If unusual oscillating movement is observed, immediately stop using the ceiling fan and contact the manufacturer, its service agent or suitably qualified persons.
16. **WARNING:** Ensure that the fan is switched off from the supply mains before removing the guard.
17. This appliance is not intended for use by persons (including children) with reduced physical, sensory or mental capabilities, or lack of experience and knowledge, unless they have been given supervision or instruction concerning use of the appliance by a person responsible for their safety.
18. **WARNING: TO REDUCE THE RISKS OF FIRE, ELECTRIC SHOCK OR INJURY TO PERSONS, OBSERVE THE FOLLOWING:**
 - A. Use this unit only in the manner intended by the manufacturer. If you have any questions, contact the manufacturer.
 - B. Before installing, servicing or cleaning unit, switch power off at service panel and lock service panel to prevent power from being switched on accidentally.
19. **WARNING:** This product is designed to use only those parts supplied with this product and/or accessories designated specifically for use with this product. Using parts and/or accessories not designated for use with this product could result in personal injury or property damage.
20. This appliance can be used by children aged from 8 years and above and persons with reduced physical, sensory or mental capabilities or lack of experience and knowledge if they have been given supervision or instruction concerning use of the appliance in a safe way and understand the hazards involved.
21. Children should be supervised to ensure that they do not play with the appliance.
22. Fan suspension system shall be examined regularly, at least once every two years.

MOUNTING/INSTALLATION OF THE FAN

Before touching a screw driver thoroughly read these instructions.

Warning/Caution: Before installing fan, turn off power at service panel and check all visible screws and bolts for tightness.

1. Remove the decorative canopy bottom cover from the canopy by turning the cover counter clockwise. (Fig. 1)

2. Remove the hanger bracket from the canopy by removing the 1 of 2 screws from the bottom of the hanger bracket and loosening the other one a half turn from the screw head. Next, turn the canopy counter clockwise to remove the hanger bracket from the canopy. (Fig. 1)

3. Secure the hanger bracket to the ceiling. (Fig. 2)

4. Remove hanger ball from down rod assembly by loosening set screws, removing the cross pin and sliding ball off rod. (Fig. 3)

5 A. **Metal Blades:** If your fan is one with metal blades, remove protective plastic sleeve from the motor shaft and attach the metal blades and cages now. Make sure that the set screw in the blade hub is counter-sunk into the bore hole in the shaft of the motor. Attach cage next.

5 B. **Wooden Blades:** If your fan is one with wooden blades, attach your blades as the last step in the assembly process. Do not attach them now. Attach them in step No.: 9. Handle your blades carefully otherwise you will bend the blade-irons and cause your fan to vibrate when in use.

6. Loosen the two set screws and remove the threaded pin from the top coupling of the motor assembly. (Fig. 4)

7. Carefully feed the fan wires up through the down rod. Insert the down rod into the coupling then tighten the threaded pin and two allen set screws. (Fig. 4) Carefully reinstall hanger ball onto rod being sure that cross pin is in correct position, the set screw on hanger ball is tight and wires are not twisted.

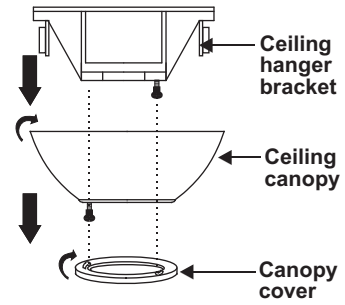

Figure 1

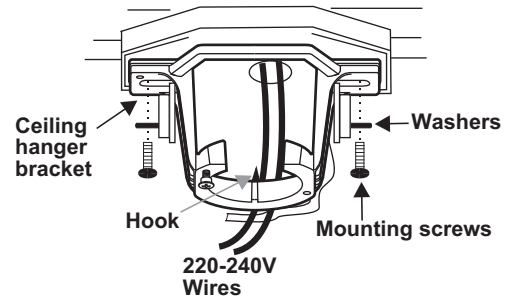

Figure 2

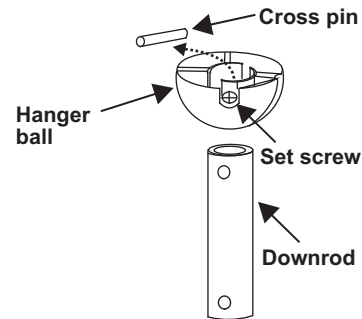

Figure 3

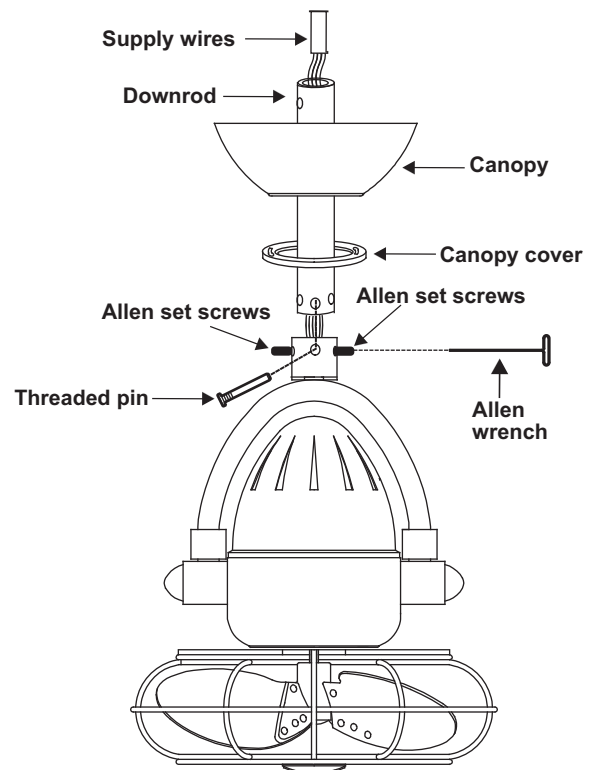

Figure 4

8. Now lift the motor assembly into position and place the hanger ball into the hanger bracket. Rotate until the "Check Tab" has dropped into the "Registration Slot" and seats firmly. The entire motor assembly should not rotate if this is done correctly. (Fig. 5)

9. Remove protective plastic sleeve from the motor shaft and attach your wooden blades. Ignore this step if you have metal blades, as they should already have been installed. Make sure that the set screw in the blade hub is counter-sunk into the bore-hole into the shaft of the motor.

10. An additional safety support is provided to prevent the fan from falling. Secure the safety cable to the ceiling joist with a screw and washer. (Fig. 5). **NOTE:** Ensure the safety support is the correct length for your down rod. If you are using a short downrod please adjust the safety support cable to 300mm max (12") longer than the downrod. IE: There should be 300mm max (12") of safety support cable coming out the top of the downrod

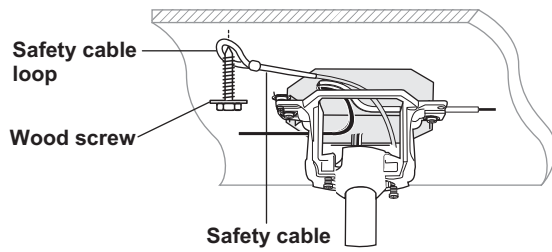

Figure 5

MAKING THE ELECTRICAL CONNECTIONS

Warning: The power should have already been disconnected. Follow the steps below to connect the fan to your household wiring. Loosen the screws on the terminal block, insert the wire to each terminal block and re-tighten the screws loosened previously. Make sure there are no loose strands or connections.

NOTE: The Hand Held Remote Control units included with your ceiling fan are equipped with 16 code combinations to prevent possible interference from or to other remote units. The frequency switches on your Receiver and Transmitter units have been preset at the factory. Please re-check to make sure the switches on both units are set to the same positions. The frequency settings should be changed only in case of interference or if a second or more remote controlled ceiling fans are installed in the same room. Any code combination will operate the ceiling fan and light as long as the Receiver and Transmitter units are set to the same codes. (Fig. 6)

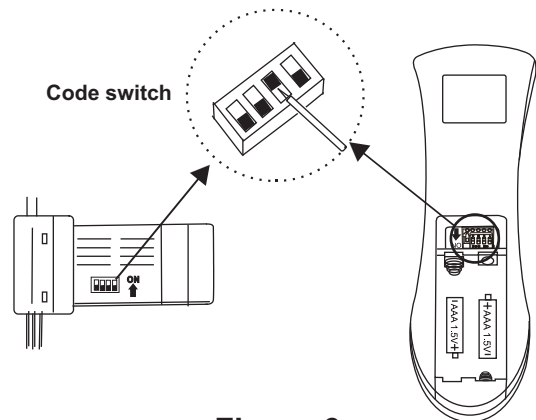

Figure 6

1. Insert Receiver into Hanger Bracket with the flat side of the Receiver facing the ceiling. (Fig. 7)

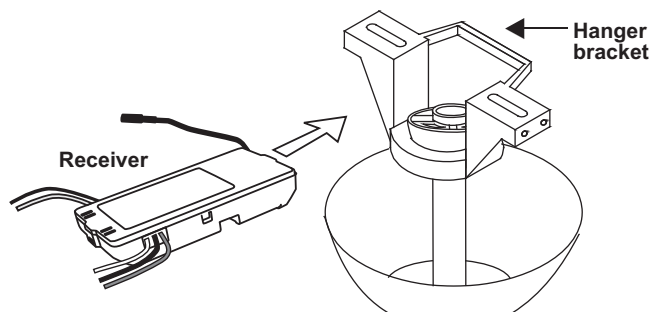

Figure 7

2. Connect the green/ground wires from the downrod ball to the terminal block “⊖” hole. (Fig. 8 & 11)

3. Connect the green/ground wires from the household and ceiling fan to the terminal block “⊖” hole. (Fig. 8 & 11)

4. Connect the blue, receiver neutral wire to the household neutral wire. Connect the brown, receiver Live wire to the household Live wire (Fig. 9 & 11). Make sure there are no loose strands or connections.

5. Connect the blue, neutral receiver neutral wire to the terminal block “N” hole. Connect the black, live receiver hot wire to the terminal block “L” hole. Connect the brown, live receiver hot wire to the terminal block “L” hole. (Fig. 10 & 11)

6. Be sure to snap together the male and female plugs. (Fig. 10 & 11)

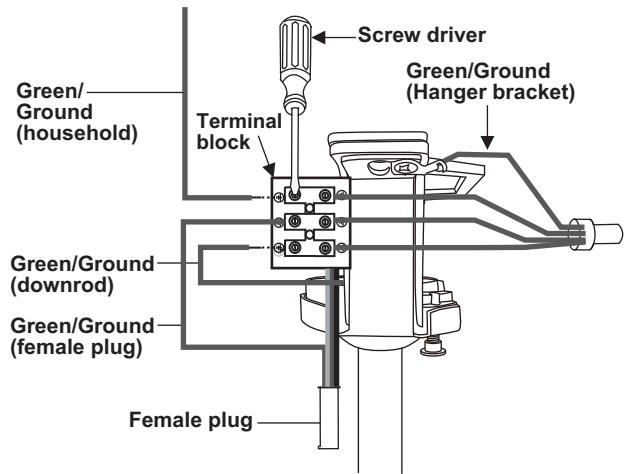

Figure 8

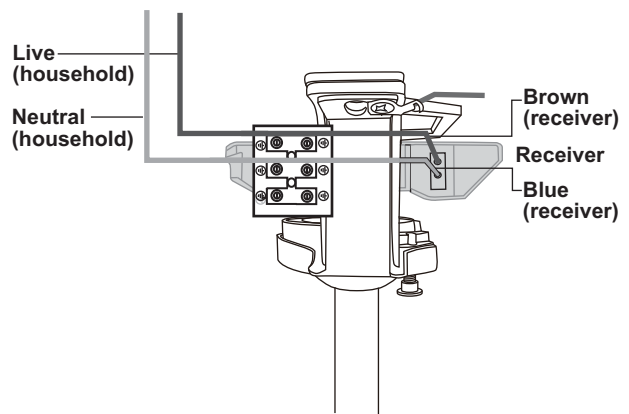

Figure 9

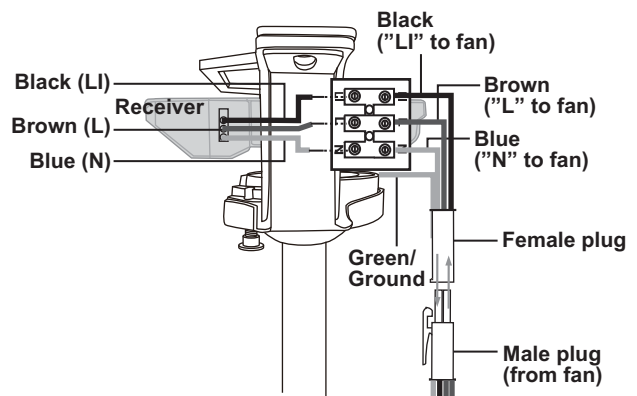

Figure 10

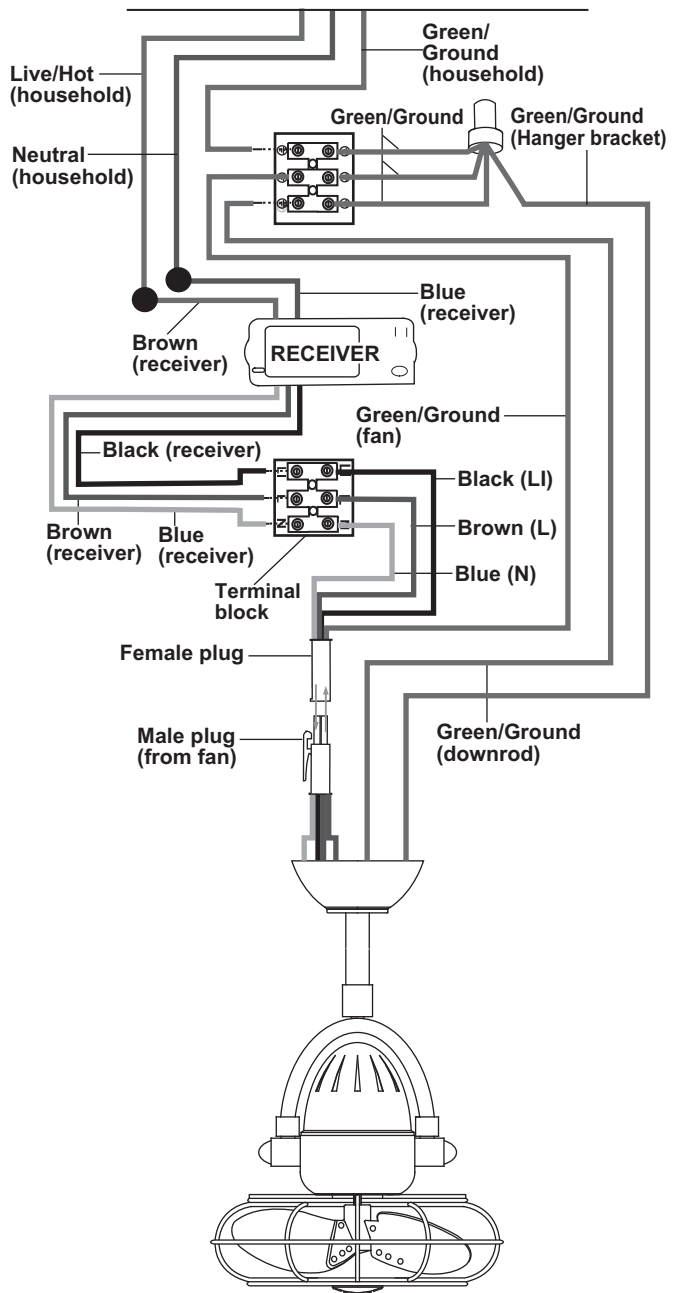

Figure 11

7. Tuck connections neatly into ceiling.

8. Slide the canopy up to hanger bracket and place the key hole on the canopy over the screw on the hanger bracket, turn canopy until it locks in place at the narrow section of the key holes. (Fig. 12)

9. Align the circular hole on canopy with the remaining hole on the hanger bracket, secure by tightening the two set screws. Note: Adjust the canopy screws as necessary until the canopy and canopy cover are snug.

Warning: Make sure tab at bottom of hanger bracket is properly seated in groove of hanger ball before attaching canopy to bracket. Failure to properly seat tab in groove could cause damage to electrical wiring.

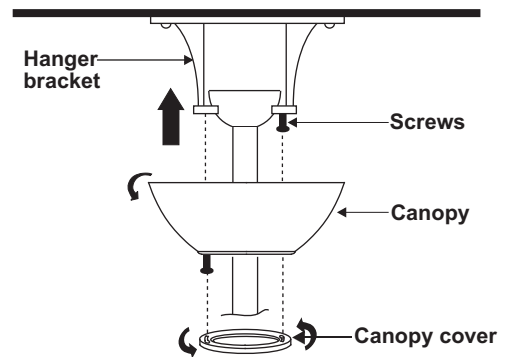

Figure 12

OPERATING THE REMOTE CONTROL

Install two 1.5V AAA batteries (included).

To prevent damage to transmitter, remove the battery if not used for long periods. (Fig. 13)

Restore Power to Ceiling Fan.

A. HI, MED, LOW Buttons:

These buttons are used to set the fan speeds as follows;

HI: High Speed

MED: Medium Speed

LOW: Low Speed

B. OFF Button:

This button turns the fan off.

C. Aux Button:

This button is used to control the oscillating operation.

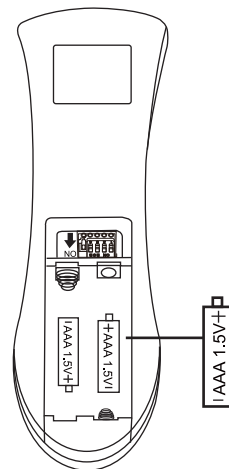

Figure 13

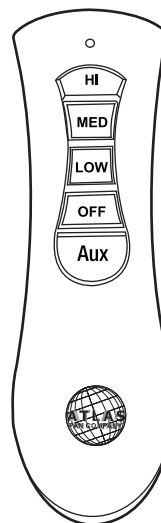

Figure 14

MAKING THE ELECTRICAL CONNECTIONS

(OPTIONAL FOR USING WALL CONTROL)

Warning: The power should have already been disconnected. Follow the steps below to connect the fan to your household wiring. Loose the screws on the terminal block, insert the wire to each terminal block and re-tighten the screws loosened previously. Make sure there are no loose strands or connections.

1. Set knobs on the wall control in the 0 position.
2. Connect the green/ground wire from the downrod ball to the terminal block. (Fig. 15)
3. Be sure to snap together the male and female plugs. (Fig. 15)
4. Connect the blue, household neutral wire to the terminal block "N" hole. Connect the brown, household Live wire to the terminal block "L" hole. Connect the black, household Live wire to the terminal block "LI" hole. (Fig. 16 & 17)

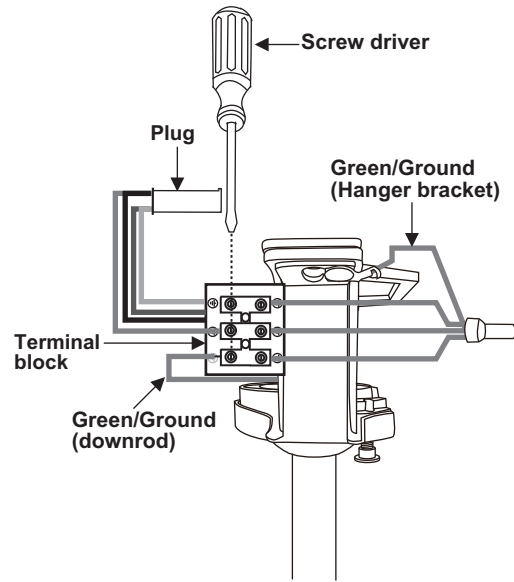

Figure 15

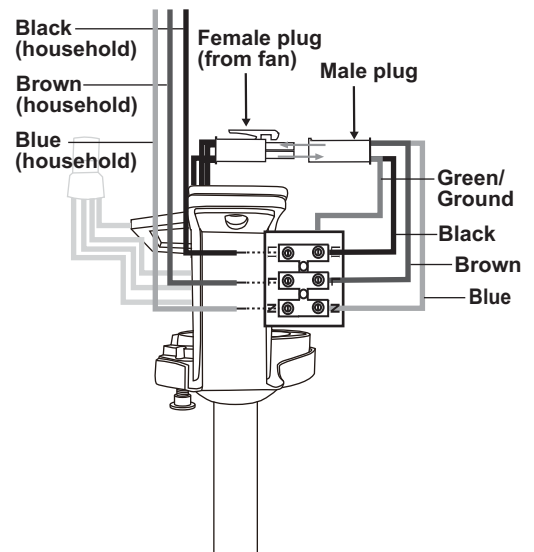

Figure 16

5. After connecting the wires, spread them apart so that the green, ground and neutral, blue wires are on one side of the outlet box and the hot, brown and the black wires are on the other side of the outlet box.

6. Tuck connections neatly into ceiling outlet box.

7. Slide the canopy up to hanger bracket and place the key hole on the canopy over the screw on the hanger bracket, turn canopy until it locks in place at the narrow section of the key holes. Note: adjust the canopy screws as necessary until the canopy and canopy cover are snug. (Fig.18)

Warning: Make sure tab at bottom of hanger bracket is properly seated in groove of hanger ball before attaching canopy to bracket. Failure to properly seat tab in groove could cause damage to electrical wiring.

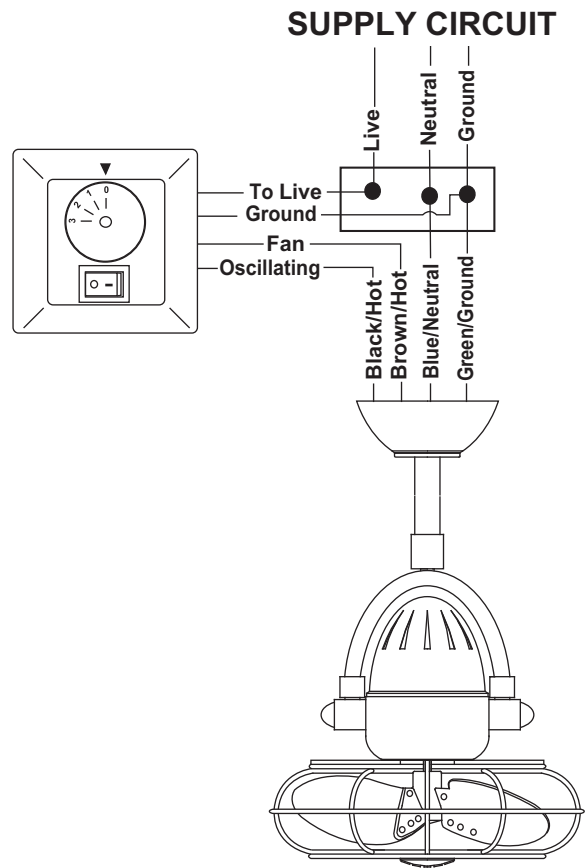

Figure 17

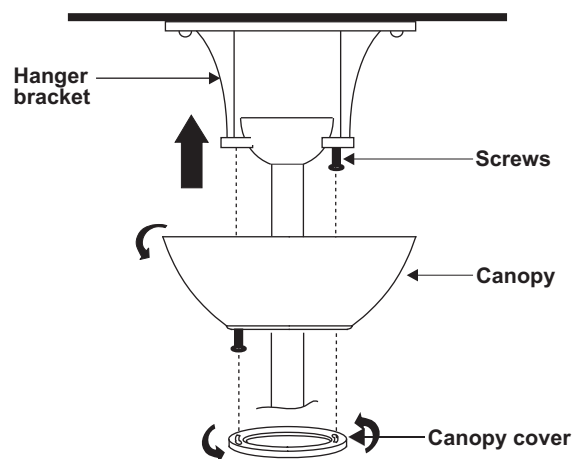

Figure 18

MOUNTING/INSTALLATION OF THE WALL CONTROL:

(OPTIONAL FOR USING WALL CONTROL)

1. Set knobs on the new, wall control in the "0" position.
2. Make speed control wire connections (Fig. 19). Ensure that bare wires are fully inserted into their terminals with no loose strands and that terminal screws are fully tightened.
 - Live wire from fan blades motor to wall speed control port labeled "Fan."
 - Live wire for light kit connection connected to wall speed control port labelled "To Light".
 - Live household supply wire to wall speed control port labeled "To Hot."
3. Connect, if present, the wall speed control's ground wire directly to one of the screws from the outlet box.

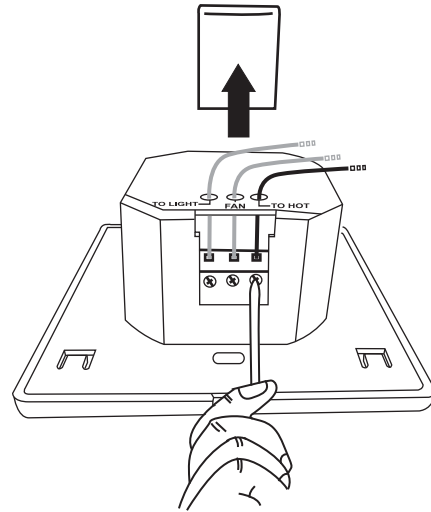

Figure 19

OPERATING THE WALL CONTROL

(OPTIONAL FOR USING WALL CONTROL)

Restore Power to Ceiling Fan.

The fan 3-speed control knob is used to control the fan blade speed as follows:

- 0= Turns the fan off
- 1= High Speed
- 2= Medium Speed
- 3= Low Speed

B. ON-OFF Button:

This button is used to control the oscillating operation if yours is a two/dual circuit installation. Otherwise, this knob will not function.

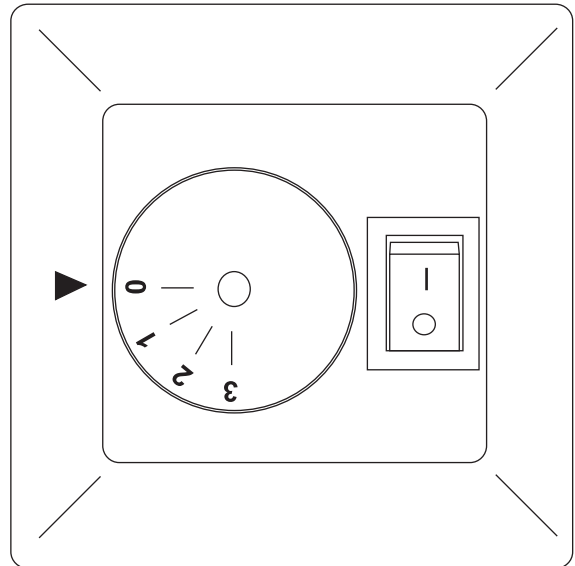

Figure 20

CARE OF AND TROUBLESHOOTING YOUR FAN

Here are some suggestions to help maintain your fan.

1. Check hardware bi-yearly. Because of the fan's mechanical movement some connections may become loose over time. Check the support connections, brackets and blade attachments twice a year. Make sure they are secure. It is not necessary to remove fan from the wall.

2. Clean your fan periodically. This will help to help maintain its new appearance over the years. Use only a lightly water-moistened, lint free cloth to avoid scratching the finish. Plated finishes are sealed with lacquer to minimize discoloration or tarnishing. Do not let rain or running water to come in contact with the fan. Rain or running water could damage the motor, wood blades or possibly cause an electrical shock.

3. There is no need to oil your fan. The motor has permanently lubricated bearings.

4. Fan makes a vibration noise. Check to see that all screws are tight in the fan cage connection to the motor face plate.

5. Fan vibrates or makes grinding noise as blades rotate. Uninstall and reinstall the blades. Make sure that your fan head's set screw is counter-sunk into the bore hole in the flat part of the motor shaft. Be careful that the blade brackets themselves are not bent in this process. Do not operate your fan if it continues to vibrate. Contact your Atlas Fan Co purveyor if the re-installation of the blades does not resolve the problem.

Caution: Ensure the fan is switched off from the mains supply before removing the guard.

NOTE: AN ADDITIONAL ALL POLE DISCONNECTION SWITCH MUST BE INCLUDED IN THE FIXED WIRING.

WARNING: All electrical connections and disconnections must be performed by a licensed Electrician.



Matthews Fan CO Atlas brand oscillation fans are mechanical and so, depending upon the amount of use your new fan receives and the climate in which it is installed, it may need its oscillation mechanism greased approximately every 6 months or as needed if oscillation noise occurs.

Step1.

Gingerly remove the motor back cap. Unscrew the x4 screws holding it to the frame while holding onto the front motor cap and blade/cage assembly so that it does not fall forward. After the x4 screws are removed, you may need to pull forward the front cap assembly a 1/4" to pull off the motor back cap. **DO NOT MOVE THE MOTOR HEAD ASSEMBLY SIDE TO SIDE, DOING SO WILL STRIP OSCILLATION MOTOR GEARS.** When the back motor cap is fully removed, replace one of the just-removed screws back into the front motor cap and frame assembly temporarily to hold the front motor cap and blade/cage in place while you grease your oscillation mechanism.

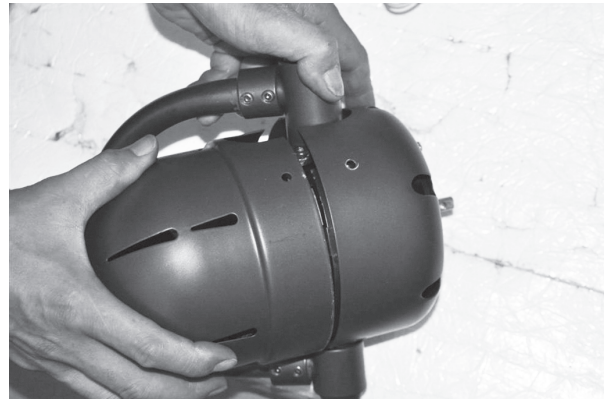
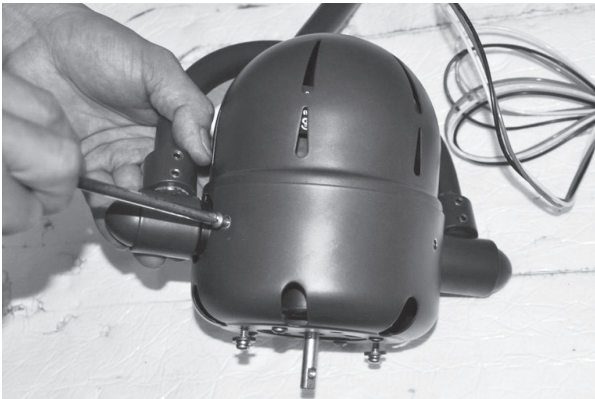

Step2.

Use a lithium based grease on all moving parts and joints of the oscillation mechanism - the push arm and cam of the oscillation motor.

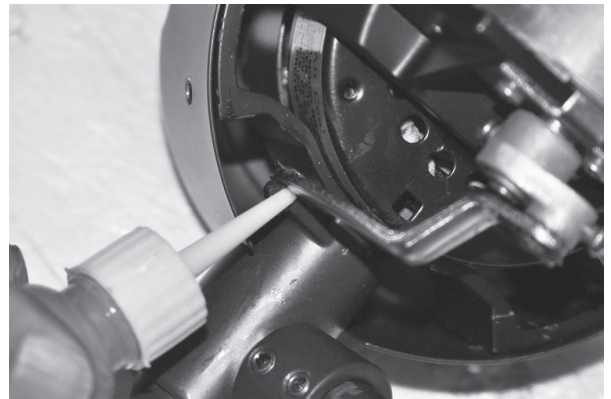
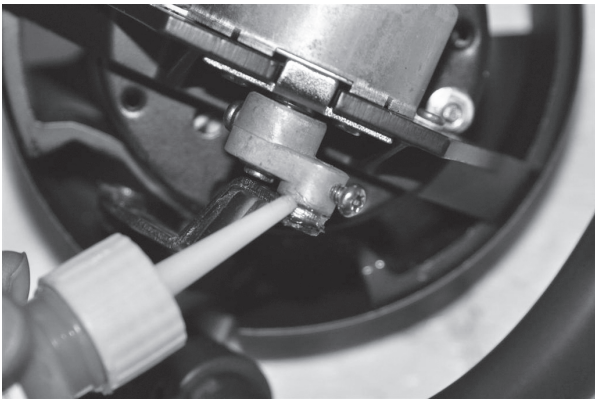

Step3.

To replace the motor back cap, hold onto the front motor cap and blade/cage assembly. Remove the temporary screw and align the screw holes between the front and back caps. Replace and tighten the x4 screws.





Manufacturer's Warranty – Australia

“Our goods come with guarantees that cannot be excluded under the Australian Consumer Law. You are entitled to a replacement or refund for a major failure and for compensation for any other reasonably foreseeable loss or damage. You are also entitled to have the goods repaired or replaced if the goods fail to be of acceptable quality and the failure does not amount to a major failure.”

For the purpose of the above paragraph specific definitions for major failure are given in the ACL Act 2010. Atlas considers major failure to be when the original, unopened and new package is missing contents, contents are damaged or defective, or the fan, light, wall or remote control does not operate when initially installed.

MOTOR:

The Atlas Fan Company (Atlas) warrants to the original consumer purchaser of each Atlas Fan ("You"), that if any part of the motor, excluding the wall controls, remote controls or pull cord mechanisms ("Controls") fails due to a defect in material or workmanship ("Defect") during your lifetime while the Atlas Fan is still installed in the exact location in which it was originally installed following the original purchase, then Atlas will provide a replacement part to you free of charge.

If any part of the motor in your Atlas Fan fails due to a defect in material or workmanship ("Defect") within 12 months after the original date of purchase by you, while the fan is still installed in the exact location in which it was originally installed, and you report this defect to Atlas immediately, Atlas will provide the necessary labour to repair the defect free of charge.

If any part of the motor excluding the wall controls or remote controls ("Controls") in your Atlas Fan fails due to a defect in material or workmanship ("Defect") more than 12 months after the original date of purchase by you, while the fan is still installed in the exact location in which it was originally installed, Atlas will provide the necessary parts only free of charge to repair the defect. You will be responsible for all labour costs incurred in repairing the defect.

CONTROLS:

If the wall control fails at any time within 12 months after the original date of purchase due to a defect, Atlas will provide the necessary parts and labour to repair the defect free of charge.

If the remote control fails at any time within 12 months after the original date of purchase due to a defect, Atlas will provide the necessary parts to repair the defect free of charge ("D.I.Y. installation"). NB: Remote controls are not part of the fan, instead being a separately connected accessory device. The remote control receiver is often fitted into the fan mounting bracket for convenience but is not an integral part of the fan and not covered by the warranty provisions of the fan itself. Resetting/Changing of DIP switches in remote controls is not covered by warranty and a service call fee WILL apply. Batteries (if supplied), are done so as a complimentary (free) item only and are not covered by warranty.

LIGHTS:

Light Globes, (if supplied), are done so as a complimentary (free) item only and not covered by warranty.

NOTES:

- Ceiling fans and fixed wiring products MUST ONLY be installed by qualified and suitably licensed person/s. A copy of your proof of qualified installation is required when claiming a warranty. (Electrical Safety Certificate)
- Warranty periods begin from the date of purchase only. A copy of your proof of purchase is required when claiming a warranty.
- When products are installed in a location requiring special access equipment (scaffolding, scissor lifts etc) the cost of providing, installing and operating special access equipment must be borne by the site owner. The need for, or use of such equipment must be stated when discussing a service call. Charges will be levied by Atlas to arrange special access equipment, and these must be paid in advance.
- If goods are found to be free of defects or the product is not functioning properly as a result of faulty installation then Atlas reserves the right to charge the customer a service fee.

Please discuss your needs with a sales professional who knows your local area and select your fan carefully. Proper performance relies on the right fan being correctly installed in the optimum location. If your fans that do not perform as expected though which are not faulty, you must refer to the retailer you bought the fan from, Atlas cannot replace or exchange under warranty.

IN-HOME (ON-SITE) WARRANTY?

The Atlas 12 month in-home warranty covers Atlas ceiling fans installed within the coverage of our network of service agents in cases where the product fails due to defective materials or workmanship. This warranty does not cover installation faults, house wiring faults, loose blades or fittings or damage of any kind. Claims regarding corrosion damage are subject to case by case appraisal. In areas outside coverage of the Atlas service agents, Atlas will reimburse consumers a standard fee of \$82.50 (inc. GST) for using their own electrician. All service requests must be arranged with the warranty department before calling your electrician. Under no circumstances will reimbursement be made for call-out fees or other costs without prior approval. When installed as recommended by Atlas (using an isolation switch) a fan or remote control can be switched off at the wall in case of a fault. If the product cannot be turned off because an isolation switch is not fitted, any electrical costs involved in disconnecting the product while awaiting warranty service are to be borne solely by the consumer.

PARTS ONLY WARRANTY?

Atlas will supply parts only, shipped directly to the consumer. Please note the labour associated with installation of these parts, or associated electrical costs of removing and reinstalling the product to affect a repair is borne by the consumer.

WHERE THE WARRANTIES WILL APPLY

These warranties will only apply where;

- The fan was purchased and installed in Australia.
- You notify Atlas of the alleged defect in the Atlas fan, its motor or its component parts immediately upon you experiencing, noticing or learning of the alleged defect;
- You provide to Atlas a copy of your 'Proof of Purchase' (Sales receipt) verifying when and from whom the Atlas fan was purchased and a copy of your 'Proof of Qualified Installation' (Electrical Safety Certificate) verifying when and by whom the Atlas fan was installed.

IMPLIED WARRANTY

All rights, warranties, conditions and remedies implied by legislation or the common law that are able to be lawfully excluded in respect of Your Atlas fan are excluded. However nothing in this clause or the manufacturer's warranties exclude, restrict or modify any condition, warranty, right or remedy, which is conferred on You by the ACL Act 2010 or any other applicable Australian consumer legislation ('Acts') or the common law and which is not lawfully able to be excluded, restricted or modified.

LIMITATION OF WARRANTIES

In addition to any limitations set out above, the warranties are limited to, at Atlas's sole option, the replacement of the Atlas fan or defective part or the supply of an equivalent product or part; the repair of the Atlas fan or defective part or the payment of the cost of having the Atlas fan or defective part repaired; or the payment of the purchase price of a replacement Atlas fan or defective part or an equivalent product or part.

Where Atlas or its authorised agents provide any services to you under or pursuant to the manufacturer's warranties, the application of the manufacturer's warranties to such services is limited, at Atlas 's sole option, to the supplying of those services again, or the payment of the cost of having those services supplied again.

WHERE THE WARRANTY WILL NOT APPLY

The warranties above are void and Atlas disclaims any liability of whatsoever any nature where:

- The Atlas fan is not purchased by you in Australia and installed in Australia;
- The Atlas fan is not installed correctly in accordance with Atlas's installation guide, or is installed in an unsuitable location;
- The Atlas fan is removed from the particular location in which it was originally installed following the original purchase, except where that removal:
 - > is expressly authorised by Atlas or Atlas's authorised agent; and
 - > does not cause, contribute to or result in, any further Defects to the Atlas fan or any of its component parts or other parts; or
- The Defect is caused by:
 - > the improper, incorrect or incomplete installation;
 - > the improper or incorrect use or adjustment of the Atlas fan by you or any third party;
 - > any attempted or completed maintenance, repair or modification carried out on the Atlas fan or its component parts or other parts by you or any unauthorized third party;
 - > the direct or indirect acts of you or any third party;
 - > normal wear and tear to the Atlas fan or any of its parts;
 - > faulty or unsuitable wiring in the structure to which the Atlas fan is fixed or connected;
 - > inadequate support in the structure to which the Atlas fan is fixed or connected;
 - > blown fuses or damage caused by force-majeure, electrical surges, lightning, power grid fluctuations, or by connection to alternative power supply sources (such as solar inverters etc) or
 - > water damage and or moisture.

Note: Signals sent through the power grid by the electricity supplier for the control of off peak hot water, street lights and other devices may cause an intermittent humming noise in your electrical appliances such as your ceiling fan. Filters are available in Australia at the customer's expense. These noises do not occur as a result of a faulty fan.

CONSEQUENTIAL OR INCIDENTAL DAMAGES

In no event shall Atlas be liable under its warranties for any consequential, incidental, direct or indirect loss, expense or damage suffered by you or any third party arising from or in relation to the Atlas fan, any of its Component Parts or other parts or any Defect.

Atlas will not be liable for any expenses incurred by you in making a claim under these express warranties, including without limitation, expenses incurred in disconnecting, reinstalling, transporting or packaging the Atlas fan where it, a Component Part or other part is to be repaired or replaced under any of these express warranties.

FOR ADDITIONAL INFORMATION REFER TO THE OWNER'S MANUAL PROVIDED WITH YOUR ATLAS FAN

TO MAKE A WARRANTY CLAIM:

To make a warranty claim, you must supply Prestige Fans with a copy of your proof of purchase, together with a copy of your proof of qualified installation (Installers invoice or electrical safety certificate). You must also explain exactly what the nature of the problem is, the address at which the fan is installed, the room in which the fan is installed, the type of wall or remote control being used, as well as any light globes used in attached light kits. You must also supply your name, address and contact phone numbers, and your claim will be dealt with.

Australian Agent:

Prestige Fans Pty Ltd

PO Box 5050 Ringwood VIC 3134

Ph: 03 9876 8287 (Extension 2)

Fax: 03 9876 8282

Email: service@prestigefans.com.au